

R-Series

Raptor Mill

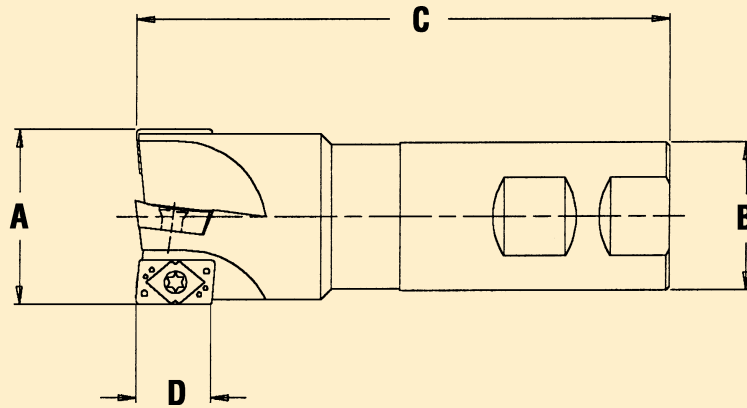

Cut Diameter (A)	Catalog Number	Shank (B)	OAL (C)	C.E.L. (D)	# of Inserts	Insert	Insert Screw
.375"	R-IPR-375-AP10-0-2(1)	.500"	3.00"	.400"	1	APKT-100308	TX-1153
.500"	R-IPR-500-AP10-0-2.5(1)	.625"	3.25"	.400"	1	APKT-100308	TX-1153
.625"	R-IPR-625-AP10-0-2.5(2)	.625"	3.25"	.400"	2	APKT-100308	TX-1153
.750"	R-IPR-750-AP10-0-3(3)	.750"	3.38"	.400"	3	APKT-100308	TX-1153
1.00"	R-IPR-1-AP10-0-3(3)	.750"	3.38"	.400"	3	APKT-100308	TX-1153
1.25"	R-IPR-125-AP10-0-4(4)	1.00"	3.75"	.400"	4	APKT-100308	TX-1153
1.50"	R-IPR-150-AP10-0-4(6)	1.00"	4.00"	.400"	5	APKT-100308	TX-1153
.750"	R-IPR-750-AP16-0-3(1)	.750"	4.00"	.630"	1	APKT-160408	TX-14-544S
1.00"	R-IPR-1-AP16-0-4(2)	1.00"	4.00"	.630"	2	APKT-160408	TX-14-544S
1.25"	R-IPR-125-AP16-0-5(3)	1.25"	4.38"	.630"	3	APKT-160408	TX-14-544S
1.50"	R-IPR-150-AP16-0-5(4)	1.25"	4.50"	.630"	4	APKT-160408	TX-14-544S

- Heavy-duty design allows faster feed rates

